

# GCE N(T)-Level MTL Oral Examination Briefing for Candidates

# What happens on the day of exam?

- Report to Candidates' Holding Room by **1:45pm**.

Reporting Time: 1:45pm @ **Level 5 ~ Booktique**

Bring along your:

- NRIC or Student Pass
- Entry Proof
- Notes (for revision in the Holding Room)

**(Please be on time)**

# LAYOUT OF ORAL EXAMINATION STATION

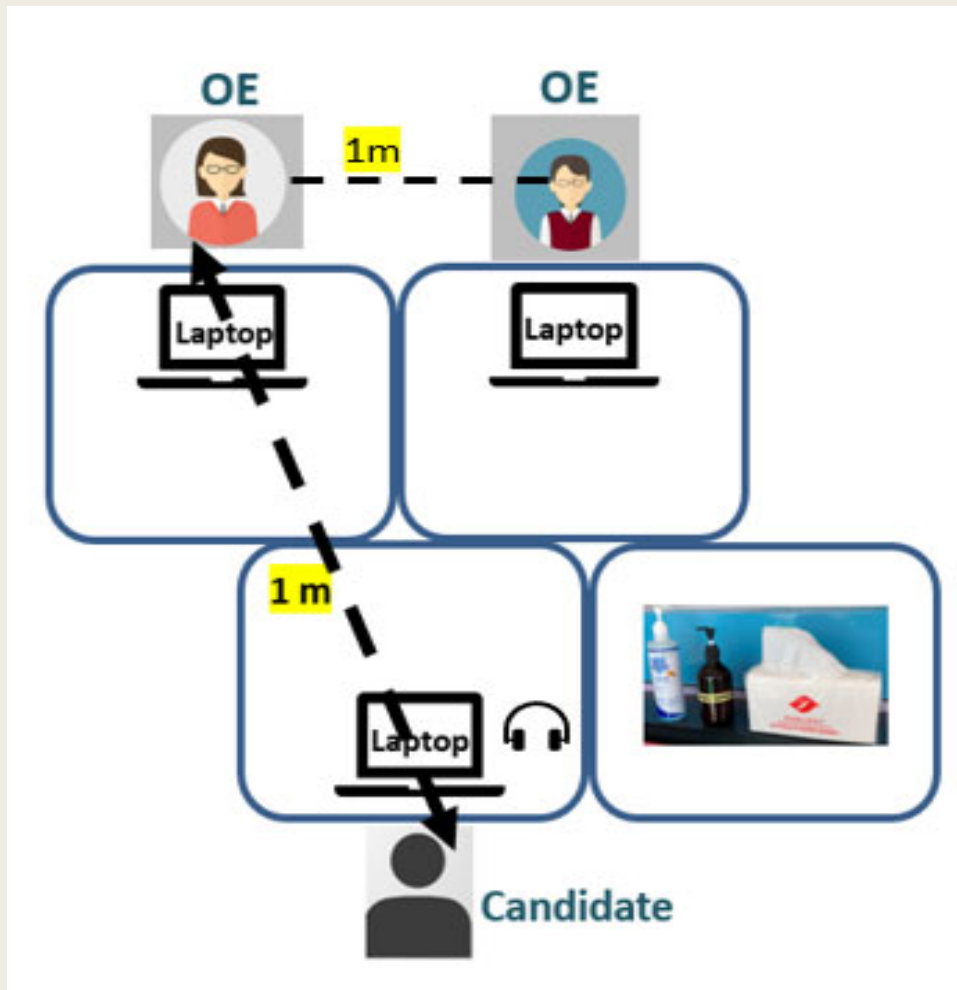

- You will sit 1.0m away from the Oral Examiners.

## AFTER THE ORAL EXAMINATION

- Proceed to the Quarantine Room to collect your belongings. (E4-03 Classroom)
- Do **NOT** communicate with other students at all times.

# Quarantine Room

- You will be held until **3.00pm**.
- You will only get your belongings back on your way out.





# **MOVEMENT IN EXAMINATION**

# Objectives

Students will

- Know what is the route to take for the examination
- Know what to do at each point



# Overall Map (Level 5)

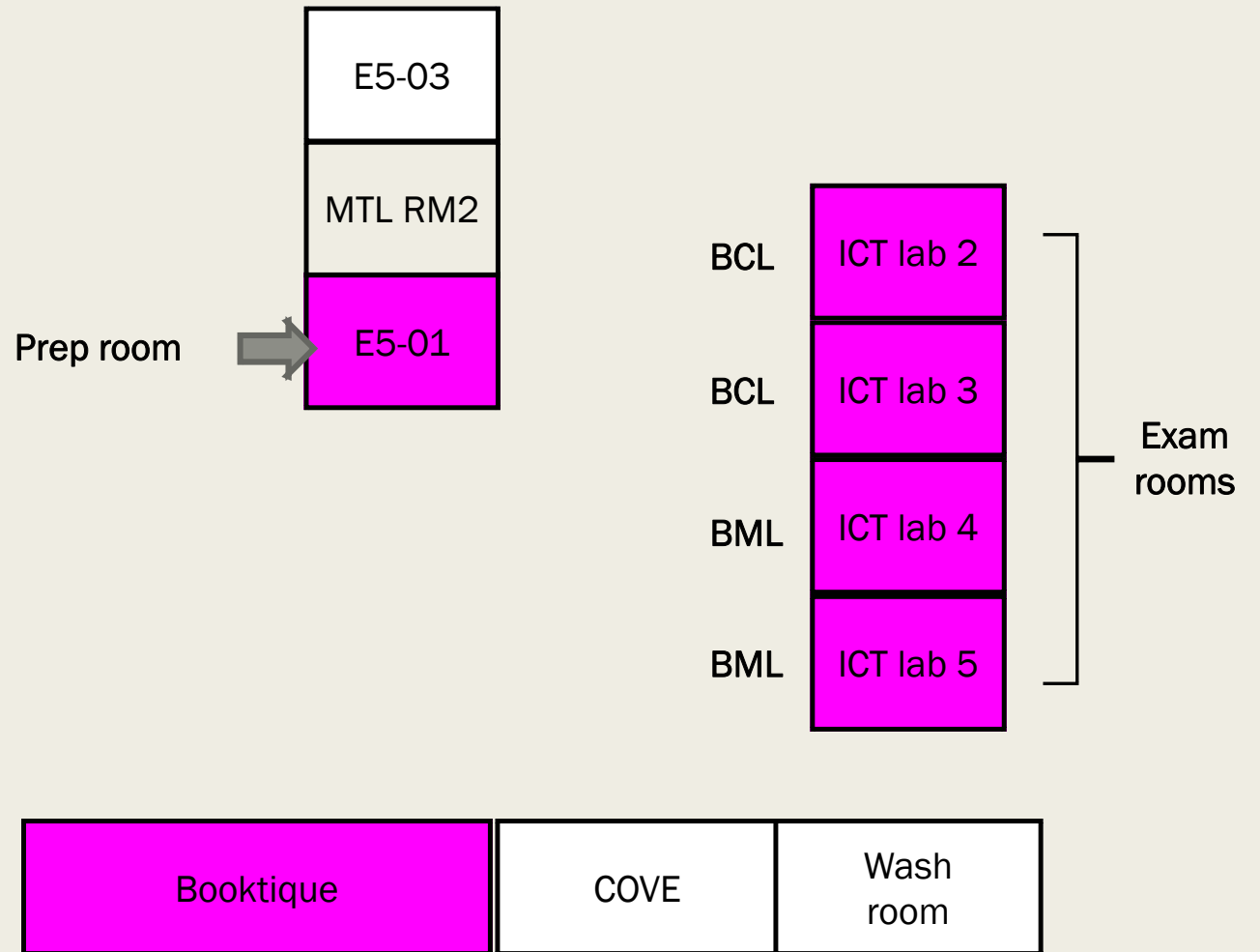

# Overall Map (Level 4)

Washroom

E04-03

CL RM2

← Quarantine room

GIANT

UNIQLO

# Step 1: Report to Holding room (Level 5)

- Report to the Library (Booktique) @ 1:45 p.m.
- Surrender belongings to the teacher:
  - *Phones (switched off)*
  - *Bags*
- Make sure you have your:
  - *NRIC / Passport*
  - *Entry Proof*
  - *Notes*

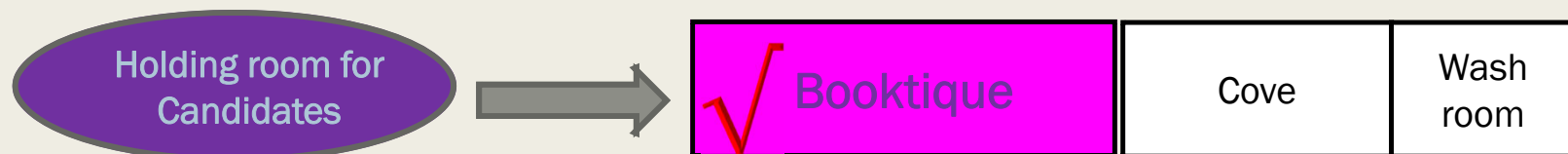
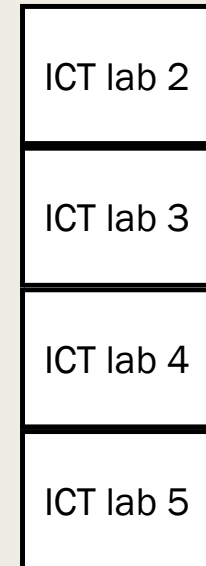
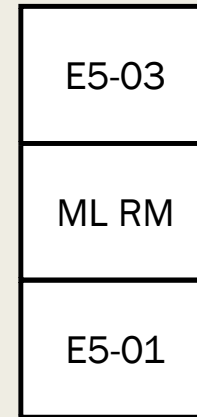

## Step 2: While at the Holding room:

- While waiting,
  - *Read your notes.*
- If you need to go to the washroom, let the teacher know
  - *You must be escorted by a teacher.*

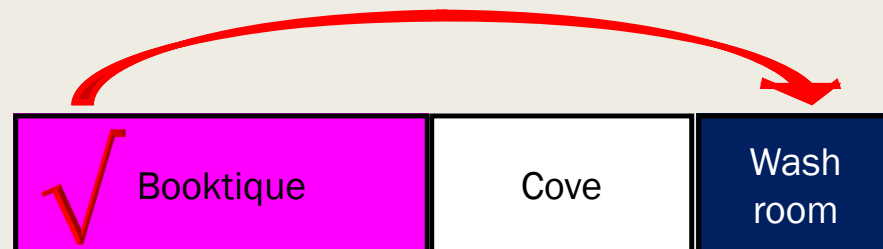
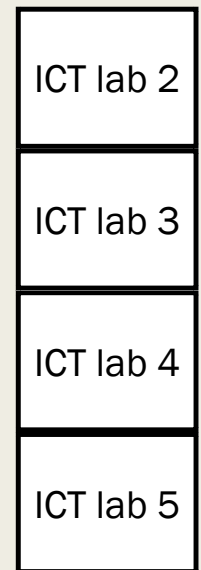
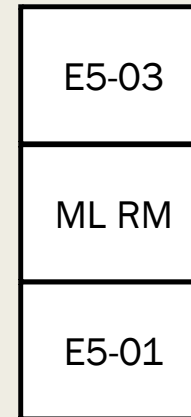

# Step 3: Move to the Prep room

- Before you go to the Prep Room,
  - *Leave your notes in the boxes (make sure your name is written clearly)*
  - *Check that you have your NRIC*
- Move to the Prep Room.

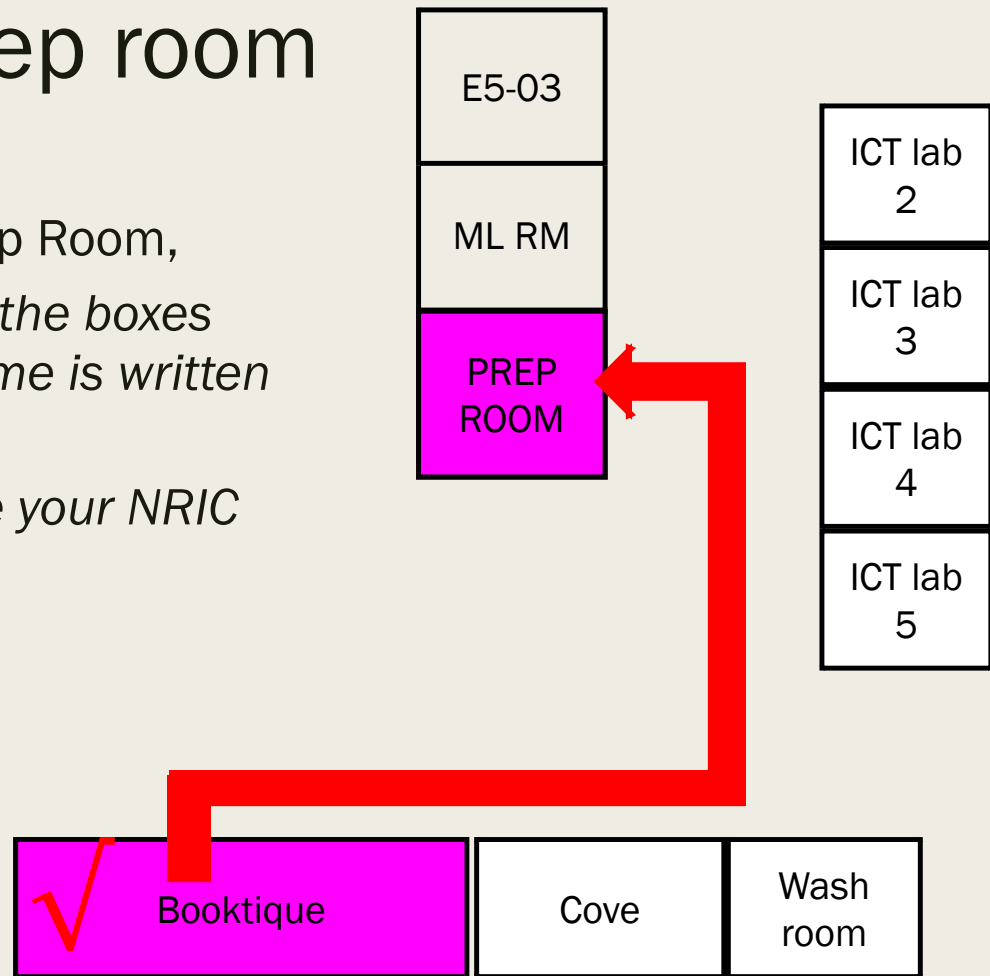

# Step 4:

## Prep room – Classroom E5-01

- Sign your attendance again.
- Enter through the back door.
- Proceed to the prep computer based on your assigned exam team.
- Key in your **User ID and Password** for the preparation.
- You will have 10 minutes of prep time.
- Once done, just wait quietly at your seat.
- Do not communicate with other candidates.

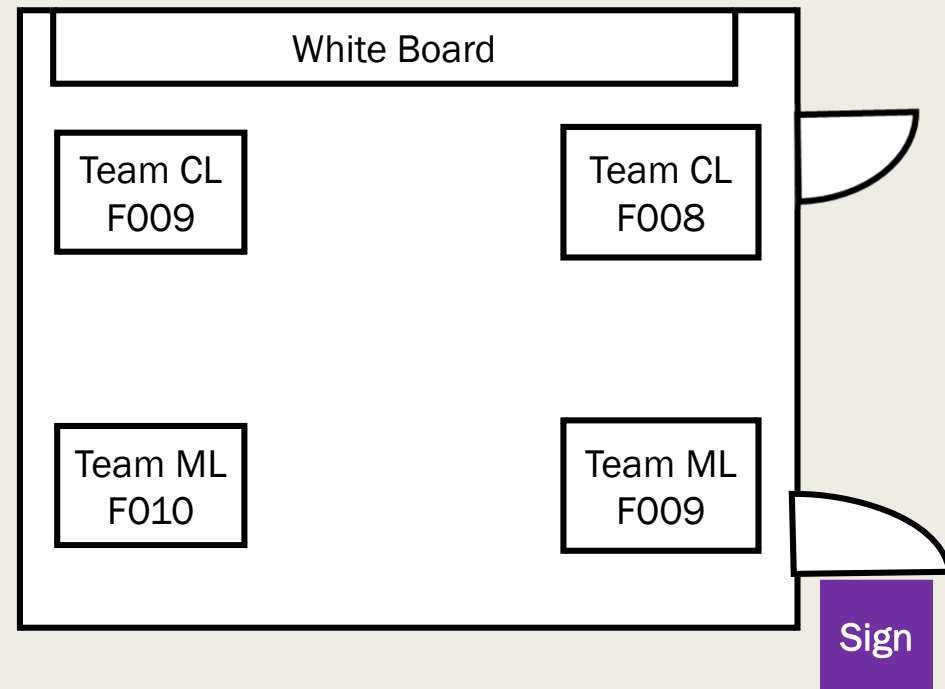

# Step 5 (BML)

## Move to Examination room (Level 5)

- Make sure you have your NRIC
- Exit through the front door

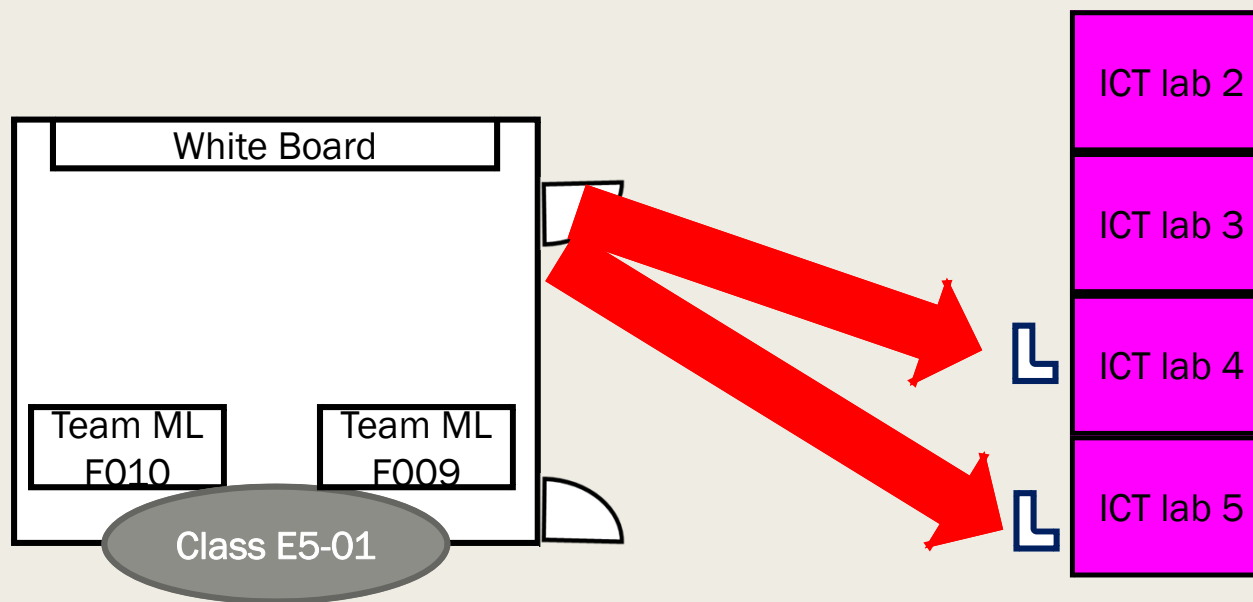

 : Chairs

# Step 5 (BCL)

## Move to Examination room (Level 5)

- Make sure you have your NRIC
- Exit through the front door

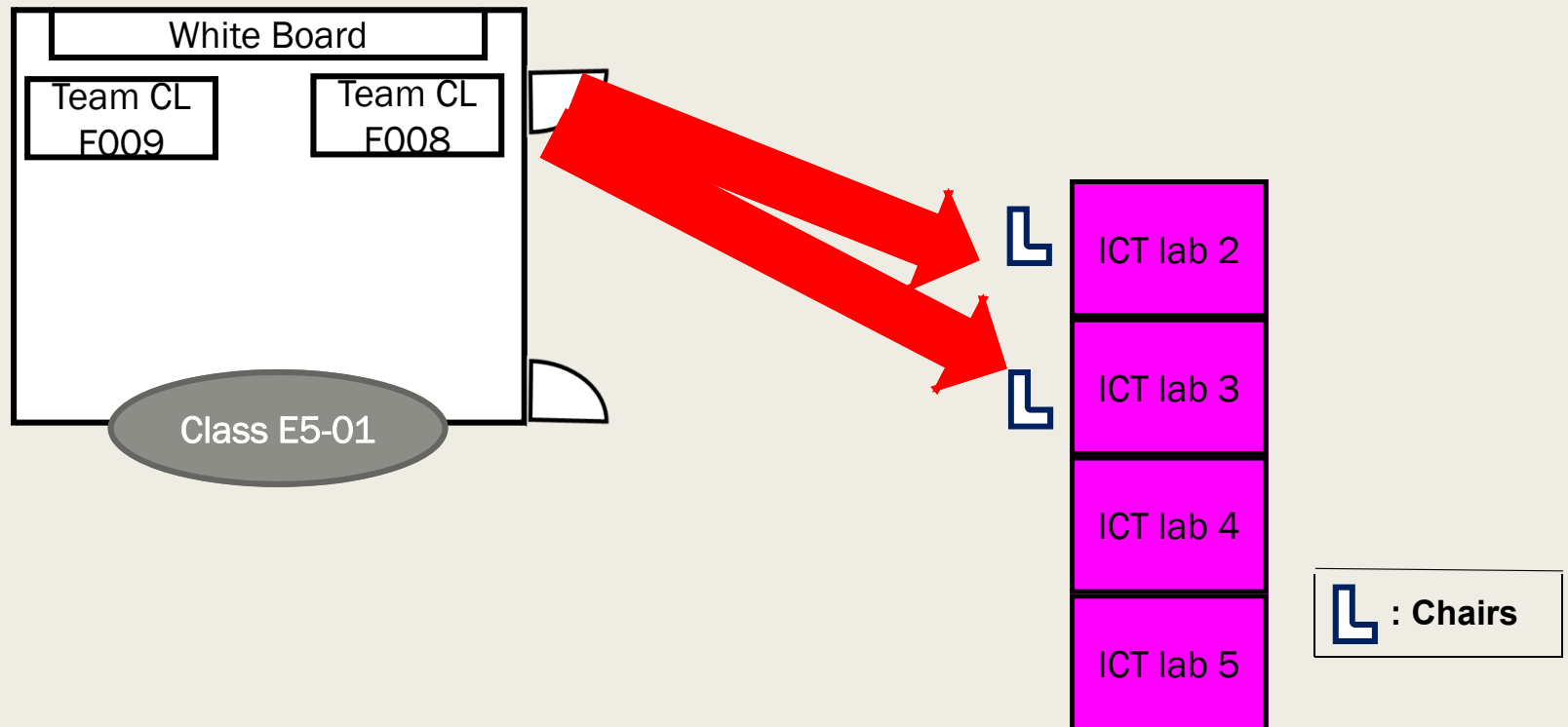



## Step 7:

# Movement to Quarantine room

The moment when you are out of the exam room,

- Do not communicate with anyone.
- Go straight to the Quarantine room.

Before 3:00pm,

- Candidates will not be dismissed yet.
- Candidates are to remain seated in the Quarantine Room quietly.

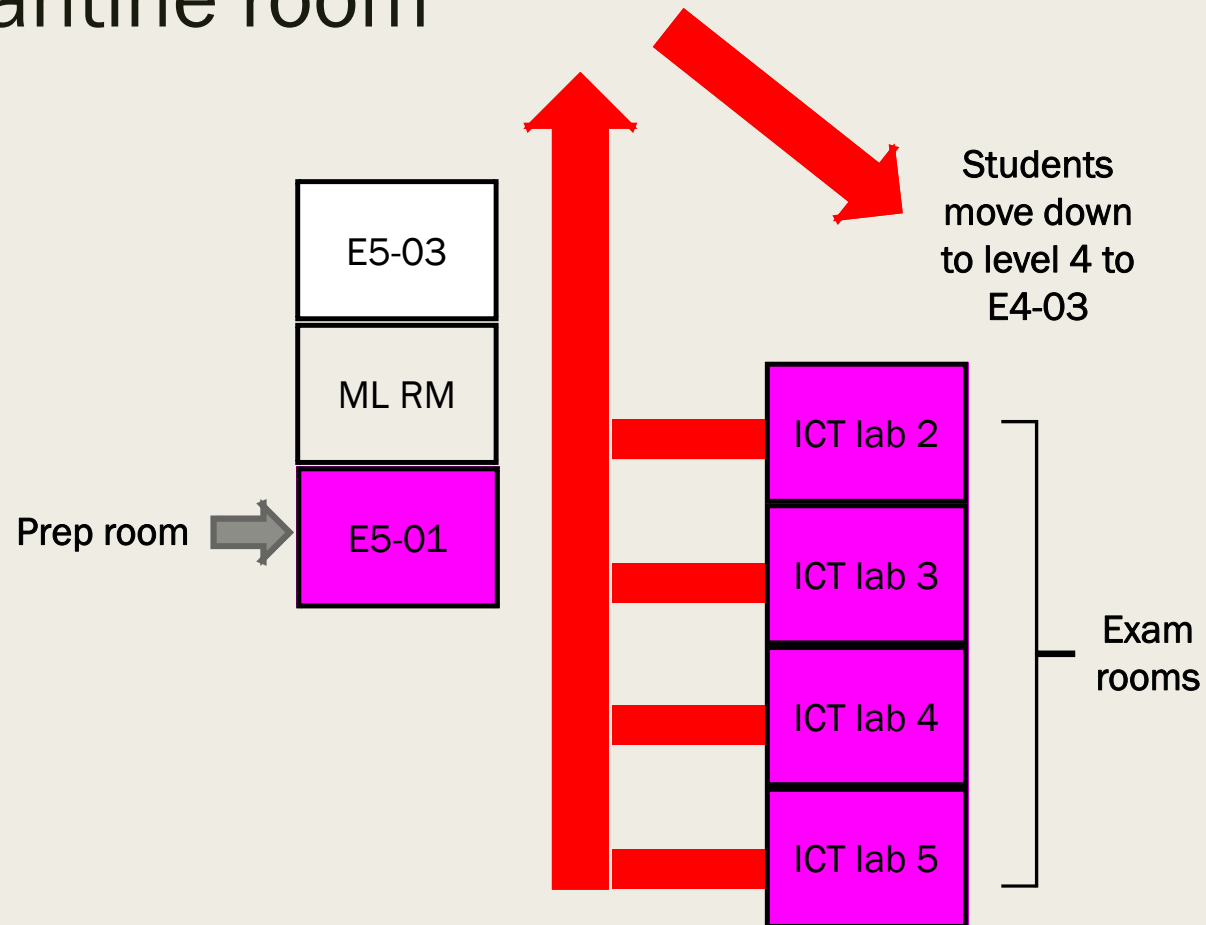

# Step 8: Exit from the Quarantine room

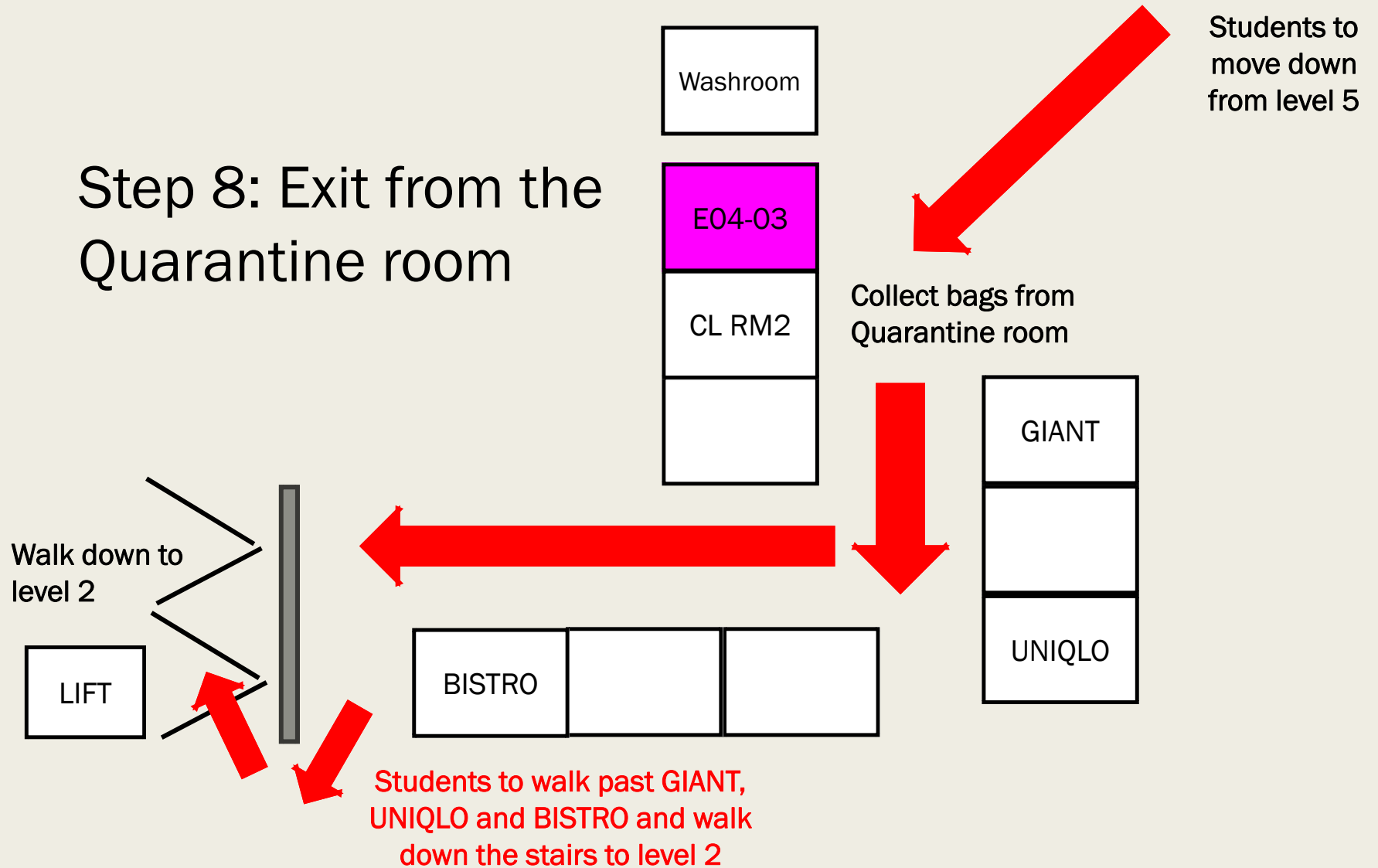

# Step 8: Exit from the Quarantine room

Level 2

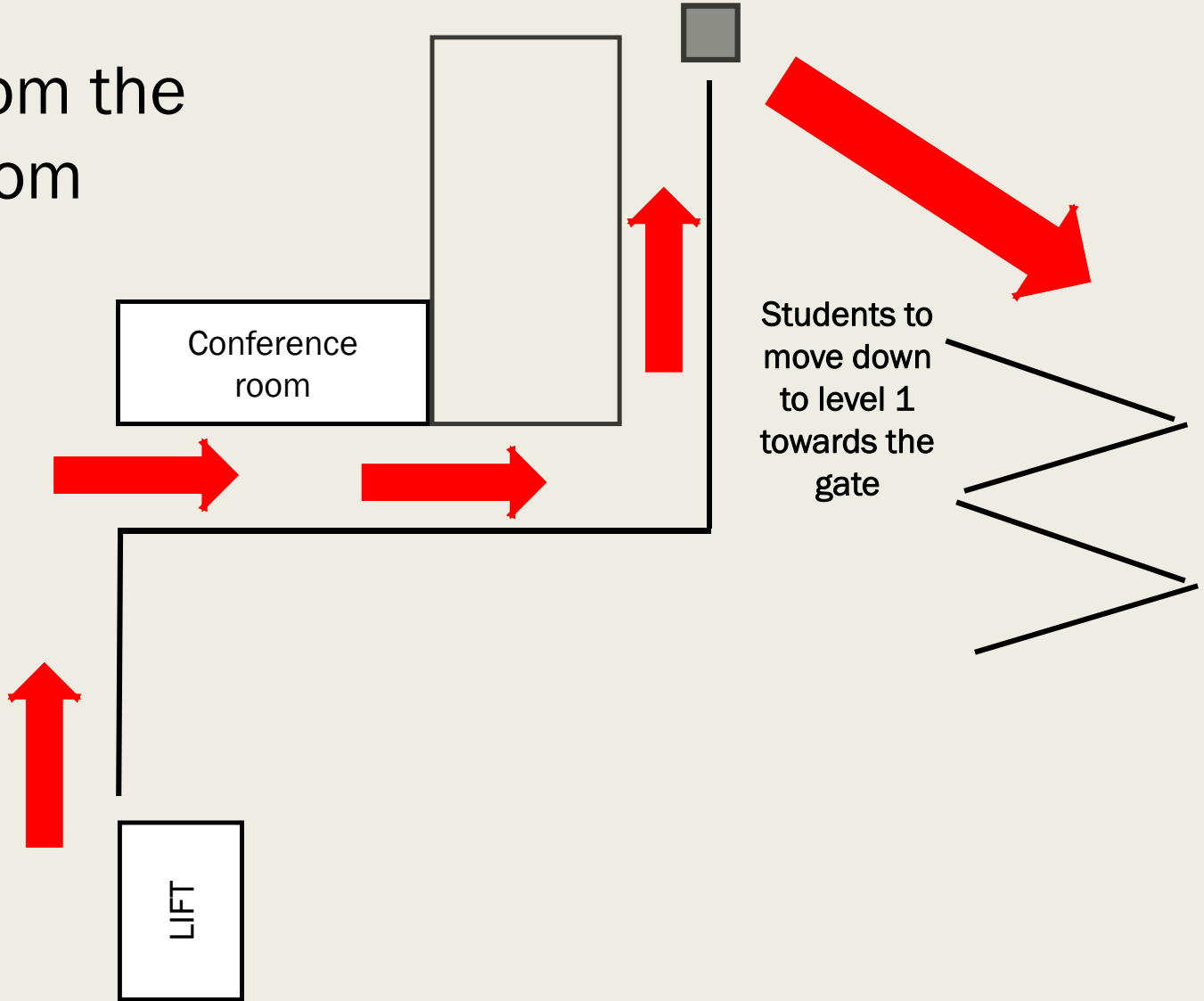
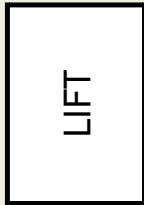
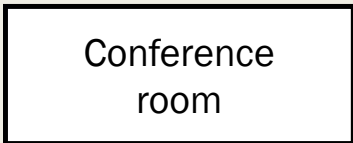
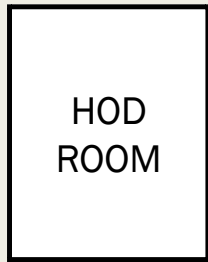



**All The Best!**